



# Aalborg HPNC Boiler

## Steam supply for deodorization and physical refining of oils and fats

The Alfa Laval Aalborg High Pressure Natural Circulation (HPNC) steam boiler is a high performance boiler developed to comply with the rigorous specifications of the food and vegetable oil industry, by ensuring high quality and reliability throughout the plant life time.

### Application

The HPNC boiler is specially designed for the deodorizing process in the physical refining of vegetable oils and fats. The boiler provides steam at high pressure and temperature to ensure an efficient deodorizing process.

The boiler operates efficiently as an integrated unit of any refining process plant for vegetable oils or fats.

The boiler can also be supplied as a stand alone unit or as replacement of existing steam boiler or thermal fluid heater.

### Design features and benefits

The HPNC boiler is supplied in 9 different standard sizes, with steam effect ranging from 125 to 2,500 kW. The standard boiler is designed to operate at steam pressures up to 90 barg.

The boiler's robust coil type design (see illustration page 2) is based on thermal fluid heaters, which ensure:

- Flexibility in absorbing thermal expansions, a feature that will ensure low stress levels in the boiler tubes and thereby also long life time
- Efficient heat transfer as gas flow is perpendicular to tube direction creating turbulence
- Efficient cooling of tube sections
- Verified pressure loss calculations (water/steam flow) that provide assurance of cooling and no overheating

Highest possible efficiency is ensured through a compact design, and reliable operation is guaranteed by using high quality instrumentation and a state-of-the-art PLC based control system.

Only high pressure grade steel tubes are used to ensure high reliability.



The Alfa Laval Aalborg High Pressure Natural Circulation (HPNC) Boiler for refining of vegetable oil and fat.

The control system and the graphical user interface ensure easy operation of the boiler and burner systems with good graphical overviews.

Furthermore, the control system provides extensive opportunities for data logging and plant surveillance, which can optimize maintenance, reduce down time and continuously provide the operator with accurate operation information.

## Working principles

The Alfa Laval Aalborg HPNC boiler is designed to operate in a closed loop system, a so called thermo syphon system, where circulation is ensured through gravity. The steam cycle is completely sealed off to remove any risk of corrosion.

Steam generation is taking place in two concentrically arranged coils – the inner coil which forms the furnace and the outer coil which provides for convective heat transfer through the second and third gas passes.

Depending on boiler size each coil can consist of one single flow way or several parallel flow ways. This design ensures sufficient and reliable circulation and thereby also cooling of all the heat transfer parts of the boiler.

As a standard our HPNC boiler systems include a steam separation cyclone to ensure dry steam supply as well as alarm free start-up and operation.

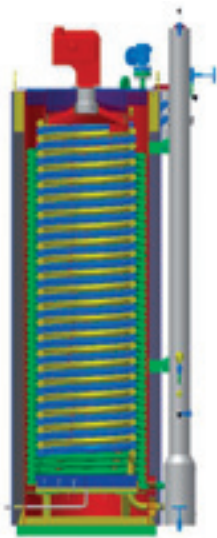

The high pressure boiler's coil type design is based on thermal fluid heaters.

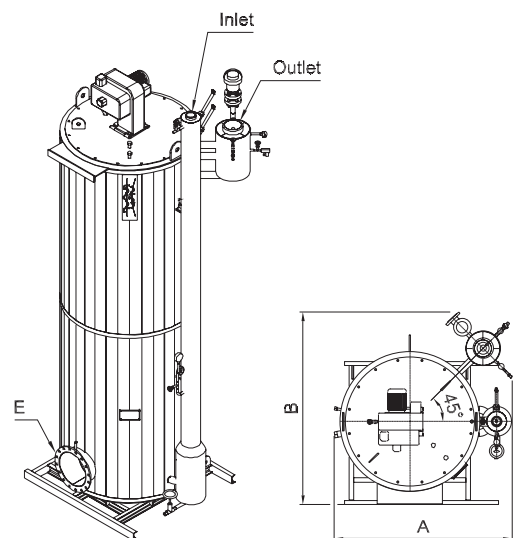
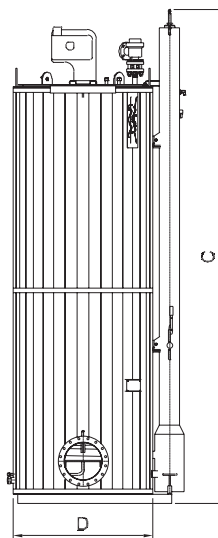

## Standard equipment

As a standard the high pressure boiler is fitted with the required accessories for a safe and reliable operation, including safety valve and low water level cut-off electrodes.

Burner equipment includes pressure jet burner for fuel oil, gas or a combination hereof as well as the required equipment for fuel line system.

The boiler system can be filled with water using a vacuum system or by using the optional high pressure filling pump.

## Optional extras

- Heavy fuel oil burner
- Air pre-heater
- Sparging steam super heater for low cost heat recovery without electrical power consumption

## Technical specifications

Max. steam output	Dimensions										Empty weight		
	A		B		C		D		E	Inlet	Outlet	kg	lb
kW	mm	inch	mm	inch	mm	inch	mm	inch	DIN86044	DN	DN		
125	1,220	48.0	1,380	54.3	2,600	102.4	815	32.1	DN200	DN80	DN100	1,000	2,205
200	1,300	51.2	1,435	56.5	2,940	115.7	898	35.4	DN200	DN80	DN100	1,250	2,756
275	1,315	51.8	1,485	58.5	3,500	137.8	966	38.0	DN250	DN80	DN100	1,550	3,417
375	1,430	56.3	1,590	62.6	3,420	134.6	1,014	39.9	DN250	DN80	DN150	1,800	3,968
600	1,680	66.1	1,670	65.7	4,270	168.1	1,136	44.7	DN350	DN100	DN150	2,400	5,291
900	1,710	67.3	1,870	73.6	4,490	176.8	1,295	51.0	DN400	DN100	DN150	3,400	7,496
1,250	2,000	78.7	1,960	77.2	5,300	208.7	1,434	56.5	DN450	DN125	DN200	4,400	9,700
1,800	2,200	86.6	2,240	88.2	6,100	240.2	1,670	65.7	DN450	DN150	DN200	6,700	14,771
2,500	2,310	90.9	2,470	97.2	6,850	269.7	1,911	75.2	DN550	DN200	DN250	10,000	22,046

For bigger capacities please contact us.

## How to contact Alfa Laval

Up-to-date Alfa Laval contact details for all countries are always available on our website at [www.alfalaval.com](http://www.alfalaval.com)